

Effects of Gas Atmosphere and Surface Quality on Rouging of Three Stainless Steels in WFI

J.E. Frantsen – T. Mathiesen
FORCE Technology
Park Allé 345
2605 Brøndby, Denmark

P. Björnstedt
AvestaPolarit AB
774 80 Avesta, Sweden

B. Henkel
HENKEL Pickling and
Electropolishing Technology Ltd
A-3830 Waidhofen an der Thaya, Austria

J. Rau
DOCKWEILER AG
D-19306 Neustadt-Glewe, Germany

J. Terävä
STERIS Finn-Aqua
04300 Tuusula, Finland

The pharmaceutical industry has for a long time been troubled by red-brown to dark violet deposits in distillation columns, storage vessels and distribution systems for water for injection (WFI), hot purified water, and clean steam. This phenomenon is known as rouging due to the visual appearance of the deposits that basically are stainless steel corrosion products. The affected installations are mostly fabricated from the austenitic stainless steel grade AISI 316L. The exact mechanism for rouge formation is not fully understood. However, it is widely reported that the phenomenon is caused by localized corrosion. On this basis an experimental laboratory technique was established to study the parameters that affect rouging. By exposing large areas of partly submerged stainless steel coupons in boiling water for 6 weeks, rouging was reproduced in the laboratory.

The obtained results showed a strong influence of the applied gas atmosphere and the coupon surface quality (finish), whereas the significance of different steel grades was questionable. None of the exposed coupons showed visible signs of localized corrosion, which suggests that rouging is a result of passive film dissolution and re-precipitation of iron rich deposits. The results from the study are correlated with examples of rouge experienced in WFI plants in the pharmaceutical industry.

Keywords: WFI, rouging, AISI 316L, EN 1.4435, EN 1.4462, EN 1.4539, gas atmosphere, welding, surface finish.

INTRODUCTION

In the pharmaceutical industry, the term rouge has for many years been used to describe the numerous cases of red-brown to dark violet deposits on the product surface of distillation columns, storage vessels and distribution systems for WFI, hot purified water, and clean steam. Owing to the visual appearance of those deposits, the phenomenon was referred to as rouge. The vast majority of the affected production equipment is made from austenitic stainless steel type AISI 316L. Furthermore, the formation of rouge is promoted by elevated temperatures above approx. 60°C.

Figure 1 shows a schematic example as to a WFI plant. Figures 2– 4 show examples of rouge experienced in WFI plants

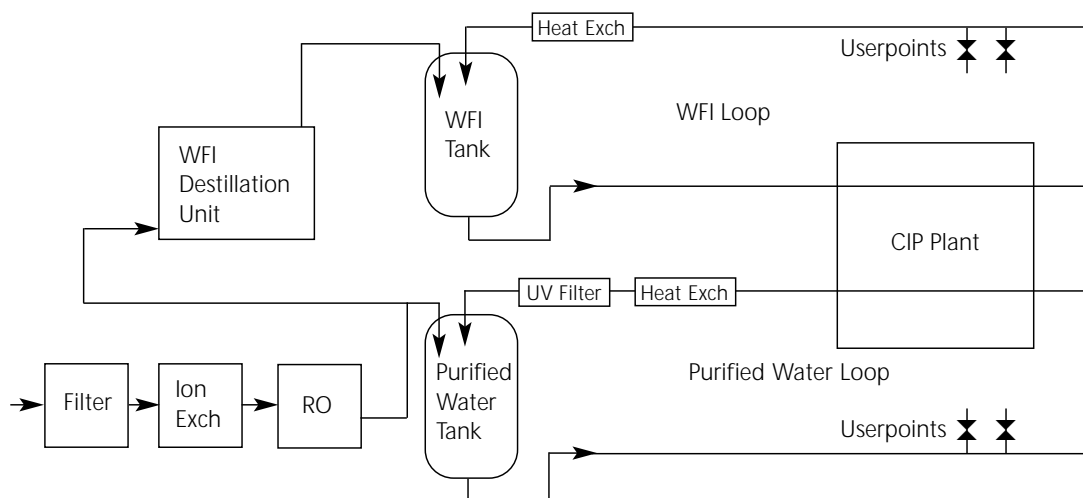

Fig 1. Schematic example as to a WFI plant.



Fig 2. Rouging in a WFI pipe arrangement.



Fig 3. Rouging in a WFI pump.

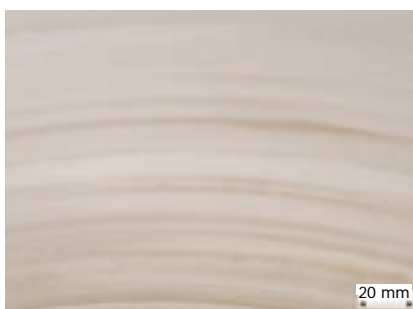

Fig 4. Rouge in a WFI buffer tank. As a result of an alternating water level, rouge has deposited on the shell in circumferential areas of varying height.

in the pharmaceutical industry. A WFI plant is characterized by a continuous re-circulation of hot water at temperatures in the interval 60–100°C.

Whereas the presence of rouge is not considered as critical for the water quality as required by the United States Pharmacopoeia XXIII⁽¹⁾, it may represent a potential risk of particulate contamination of pharmaceutical product solutions. It may therefore necessitate consistent repeated cleaning operations or proper installation of additional filters at the user points.

A literature survey gained a wide range of opinions as to the origin of rouge, e.g. localized corrosion in vulnerable areas of the passive film [1–9], poor welding including heat tint [4,8,10,11] and various surface contamination such as mild steel particles [2,7], grinding dust and residues from emery wheels [7,8,12]. Otherwise the literature is very focused on the various possibilities for

“de-rouging” of pharmaceutical water systems [3,5,8,10,13,14]. The two most widely used media for de-rouging are acids and chelates. Few articles have been published regarding experimental work as to rouge [10,15].

In 1997, Jessen [16] reported that the formation of rouge was greatly influenced by the composition of the gas atmosphere, which is in equilibrium with the boiling water and the vapor phase. It was stated that a CO₂ containing and/or O₂ depleted media strengthened the formation of rouge whereas saturation with O₂ inhibited the phenomenon. These findings were the basis for the initiation of a new rouge research project in 1999. By limiting the number of parameters within each experiment, the purpose of this project was to reproduce some of the results reported by Jessen and to determine the influence of different surface qualities (finishes) and stainless steel alloys.

⁽¹⁾ According to the United States Pharmacopoeia XXIII, the conductivity value of WFI may not exceed 1.25 µS/cm at 25°C.

EXPERIMENTAL PROCEDURE

Materials and preparation

Coupons for exposure tests were produced from 2.0 or 2.5 mm plate material of the stainless steel grades shown in Table 1. Each coupon measures 100x100 mm and includes a center hole ($\varnothing 12$ mm) and a weld. The welding procedure applied (GTAW⁽²⁾) ensured a δ -ferrite content of less than 5% for the austenitic grades (EN 1.4435 and EN 1.4539), and between 30–70% for the duplex EN 1.4462 grade. Both sides of the weld seam were pickled with a hydrofluoric acid (HF) and nitric acid (HNO₃) based paste. Since rouging often is associated with welds that inevitably occur in WFI systems, it was chosen only to include welded coupons in the exposure tests.

In order to test extreme surface qualities, the coupons were prepared in either the original finish,

a ground or electropolished finish. The major characteristics of the tested materials are summarized in Table 2. The ground finish was produced using aluminum oxide fiber disks (P80). Electropolishing and follow-up treatment was strictly controlled and performed in concentrated phosphoric/sulfuric acid solutions at about 50°C according to HE111-processing (material removal approx. 20 μ m). The final treatment for all coupons was chemical passivation in 20% HNO₃ for 30 minutes at ambient temperature followed by de-ionized water rinsing.

Exposure

During exposure the coupons were mounted on a PTFE⁽³⁾ hosed titanium⁽⁴⁾ rack. Each rack contained 30 coupons separated by PTFE⁽³⁾ spacers (1.5 mm) while PTFE strips⁽³⁾ were inserted for every third coupon. Four identical

exposure systems were built from standard laboratory glass equipment with suitable gaskets and conjunctions⁽⁵⁾. Each system included two flasks, i.e. a heated cell containing the coupon rack and a reflux flask. A constant water level was maintained by interconnecting the two cells. Each system was filled with 9 liters of WFI (conductivity approx. 1 μ S/cm at 25°C) to obtain 80% submersion of the coupons giving a total exposed area of 50 dm². The exposure tests were carried out under various gas atmospheres:

- Synthetic air.
- Synthetic air with addition of 1% CO₂.
- Synthetic air minus CO₂. CO₂ was removed by bubbling the gas through a sodium hydroxide (NaOH) solution.
- N₂ 99.999% (O₂ level < 1 ppm).

Table 1. Chemical composition (wt-%) of the Stainless Steel test materials (coupons) determined by Optical Emission Spectroscopy (OES)

EN	UNS	C	Si	Mn	P	S	Cr	Ni	Mo	N	Cu
EN 1.4435	S31603	0.018	0.51	1.71	0.030	0.002	17.3	12.5	2.6	0.059	0.16
EN 1.4539	N08904	0.014	0.28	1.50	0.021	0.001	19.6	24.2	4.3	0.053	1.43
EN 1.4462	S31803	0.022	0.38	1.53	0.022	0.001	22.4	5.7	3.2	0.117	nd.

Table 2. δ -Ferrite content in the weld metal and surface roughness of the tested materials.

Material	δ -ferrite content in weld metal (Vol-%) ^a		Surface roughness of tested finishes ^b , average Ra (μ m) ^c					
	Average	Min. / Max.	2B	2B+ep	#80	#80+ep	2E	2E+ep
EN 1.4435	3.0	1.4 / 4.1	0.22	0.18	1.03	0.39		
EN 1.4539	Not detectable						0.32	0.32
EN 1.4462	59.1	51.9 / 66.9					0.21	0.10

a) Measured with a Fischer Feritscope M11 and MP3C (both Vol.-% Fe cal.) b) 2B – according to ASTM A480, i.e. skin passed and pickled finish; 2E – annealed, electrolytically pickled, brushed (grit 100) and finally pickled; ep – electropolished finish according to HE111-processing; #80 – ground finish, mesh 80. c) Using contact profilometry (Lt 4.8mm/ Lc 0.8mm).

The systems were thoroughly purged for three days with the selected gas at a flow of 50 ml/min (mass flow controllers) before turning on the heat. Boiling was then maintained for 6 weeks at constant gas flow of 25 ml/min. Figure 5 shows an overview of the test set-up.



Fig 5. Overview of the test set-up.

Evaluation

To identify any roughing during the exposure period, the coupons were regularly inspected visually. At the end of the test, water samples were taken from each cell and analyzed for dissolved metals by use of ETAAS or HR-ICPMS⁽⁶⁾. The exposed coupons were evaluated by their weight change and visual appearance. The surface morphology was investigated using light optical microscopy (LOM) and scanning electron microscopy (SEM). The deposits collected on the PTFE strips and/or coupons were analyzed by means of X-ray fluorescence (XRF).

⁽²⁾ Gas Tungsten Arc Welding

⁽³⁾ Polytetrafluorethylene (Teflon from DuPont)

⁽⁴⁾ ASTM Grade 1

⁽⁵⁾ SCHOTT DURAN

⁽⁶⁾ ETAAS – Electrothermal Atomic Absorption Spectrometry; HR-ICPMS: High Resolution Inductively Coupled Plasma Mass Spectrometry

RESULTS

The experiments involved two series of exposure tests to study either the effect of different gas atmospheres or different stainless steel alloys. In addition, both series included different surface qualities (finishes) of the materials tested.

Variations in gas atmosphere and coupon surface quality

In the first series of exposure tests, two extreme surface qualities of EN 1.4435 were tested in four different gas atmospheres. The coupons included a roughly ground surface finish and an electropolished surface finish placed at each end of the rack. The aim of this arrangement was to prove whether different qualities possibly could be combined and distinguished in the same cell.

The first signs of rouge became visible after four days of exposure while only little development was observed during the remaining exposure period. In all cases rouge was seen as deposits along the water line of the coupons as shown in Figures 6–7. The most evident rouge formation was seen in the cells purged with N₂ or air with addition of CO₂. The two other atmospheres (air and air minus CO₂) showed less or no rouge formation. This became clear when the coupons and PTFE strips were studied closely after dismantling the cells, see Figure 8. Table 3 summarized the results of the first test series.

The visible degree of rouging is connected with an increasing



Fig 6. Test cell with a coupon rack showing rouge at the water line after 3 weeks exposure in WFI purged with N₂ (boiling was paused). The coupons include both the #80 and the 2B + ep finish of EN 1.4435 material.



Fig 7. The same coupon rack as shown in Figure 6. The rouge deposits at the water line is very distinct.



Fig 8. Teflon spacers and strips after exposure of EN 1.4435 in WFI purged with a) Air + 1% CO₂ and b) Air minus CO₂.

Table 3. Summary of results of exposure tests including EN 1.4435 materials tested in WFI at 100°C for 6 weeks. The #80 and 2B plus electropolished surface finishes were tested in the same cell.

Atmosphere	Dissolved metals ^a , µg/l				XRF-iron intensity on Teflon strips	Appearance of coupons and Teflon strips, visually assessed
	Fe	Cr	Ni	Mo		
Air	20	0.5	3.8	8.4	Weak	Traces of rouge
Air + 1% CO ₂	39	0.8	23	7.4	Strong	Heavy rouging
Air minus CO ₂	23	0.6	6.9	7.4	Weak	No rouging
N ₂	130	1.6	9.0	9.6	Strong	Heavy rouging

a) measured using HR-ICPMS (Fe, Cr, Mo) or ETAAS (Ni).

Table 4. Summary of results of exposure tests of different alloys tested separately in N₂ purged WFI water at 100°C for 6 weeks.

Stainless steel grade	Surface	Dissolved metals ^a , µg/l		XRF-iron intensity on Teflon strips	Appearance of coupons and Teflon strips, visually assessed
		3 weeks	6 weeks		
EN 1.4435	2B	431	37	Moderate	Distinct rouging
	2B + ep	177	6.8	Weak	No rouging
EN 1.4539	2E		95	Strong	Distinct rouging
	2E + ep		<2	Moderate	Slight rouging
EN 1.4462	2E		365	Strong	Slight rouging
	2E + ep		59	Weak	Very slight rouging

a) Iron content after 3 and 6 weeks of exposure. The iron content of the WFI was 2.9 µg/l.

amount of dissolved metals and the metal oxide/hydroxide deposits collected on the strips as shown in Table 3. In all cases the red-brown rouge deposits were identified as iron dominated products by XRF. Deposits analyzed by electron dispersive X-ray analysis (EDX) in an environmental scanning electron microscope (ESEM) revealed the presence of other alloying elements (chromium, nickel, molybdenum) and showed only small amounts of carbon (0.9–2.4 wt-%) in comparison to the high amount of iron (30–50 wt-%). It should be mentioned that the same technique detected the presence of silicon as colorless deposits on the coupons. The glassware is the most likely source for the dissolved silicon. Due to the deposition of silicon, the weight

change results could not be utilized to evaluate rouge formation. Microscopic investigation of the coupons surface showed that the rouge product consists of relatively loosely adherent particles, see Figure 9. The rouge was evenly distributed on all the investigated strips and coupons. Consequently, the first series of tests did not allow any distinction between the different surface qualities.

Variations in stainless steel alloys and coupon surface quality

Based on the experiences gathered during the first series of tests, the second series of tests were performed with only one set of material and surface quality in each cell. In order to produce the most extreme conditions as

regards rouging, all tests were performed in N₂ purged atmosphere. From the results in Table 4, it is evident that the specified and controlled electropolished finish of all stainless steel alloys showed less rouging than their untreated counterparts. Furthermore, the untreated finish of the high stainless steel alloys revealed no obvious improvement in performance when compared to the EN 1.4435 2B finish.

In agreement with the above-mentioned results, the metal concentrations are higher in the water samples from the unpolished plates whereas the electropolished counterparts show less dissolved metal (Table 4). During the exposure tests, additional water samples were taken after 3 weeks (EN 1.4435 only). It clearly

appeared that all coupons released high amounts of iron although the visual rouge formation at that time was limited. Moreover, the iron content in water samples exposed for 3 weeks was higher than in water samples after 6 weeks. This difference may possibly be due to an initial high release rate of iron and subsequent slow deposition. It should be mentioned that silicon from the glassware was also present in the water samples at concentrations that were approximately 1 000 times higher than the metal concentrations.

Microscopy investigations of the exposed coupons were undertaken to identify any signs of corrosion. None of the coupons showed obvious indications of corrosion, although the electropolished coupons clearly revealed all forms of imperfections or inhomogeneous structures such as small slag particles or weld areas. The δ -ferrite phase in the welds also appeared clearly on

the electropolished coupons but showed no indications of selective dissolution, see Figure 10. It is more difficult to exclude the possibility of corrosion on the other surfaces since the evaluation was disturbed by either the intergranular etching (2B finish) or grooves (2E finish).

DISCUSSION

The results show several interesting features on the rouge formation on stainless steel in boiling WFI. Firstly, the tests consistently show that rouge is an iron rich product consisting of small particles that accumulate preferentially along the water line or on the PTFE parts. This indicates that the particles are formed at the water level and float until they deposit in stagnant areas at the water/gas interface or on PTFE parts due to electrostatic forces. Rouge is also deposited to a lesser degree below the water level at the PTFE spacers, which verifies that the metal dissolution

takes place in the water phase. Unfortunately, this behavior implies that different steel qualities could not be tested together.

The first series of exposure tests shows a strong effect of the gas atmosphere composition although the tests show no significant distinction between the two surface qualities in each cell. The most evident rouge formation is observed in the cells purged with N_2 or air with addition of CO_2 , whereas air and CO_2 depleted air show less or no rouge formation. This result indicates a beneficial effect of O_2 and a negative effect of CO_2 that respectively may improve the stability of the passive layer and cause a slight acidification (carbonic acid) of the media. It should be noted that the final pH was 5.5 of the CO_2 containing media whereas the pH in the other media ranged from 7.6 to 8.1. WFI completely purged of all gases was not included in the study, but would probably result

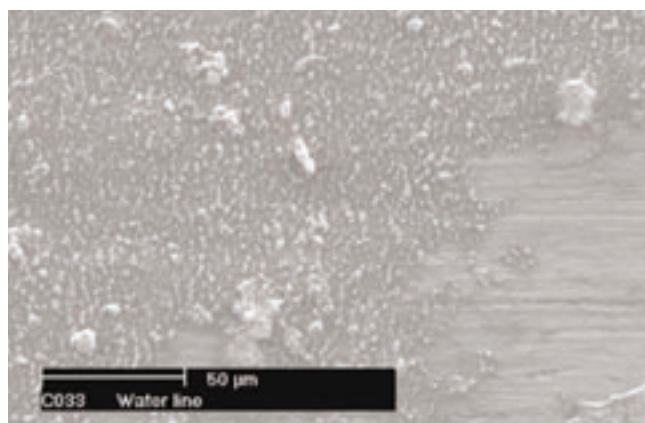

Fig 9. Scanning electron micrograph showing exposed coupon covered by loosely adhered rouge deposits.

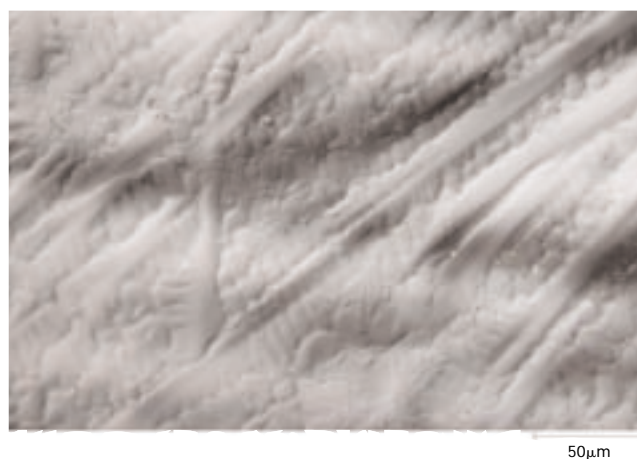

Fig 10. Weld metal of an electropolished EN 1.4435 coupon. The picture was obtained by light microscopy and shows a small amount of δ -ferrite distributed as a skeleton between the primary austenitic phase.

in the same behavior as observed for the N_2 purged experiment, assuming that the obtained O_2 depleted conditions in both cases have the same effect on the passivation of the stainless steel.

With respect to the effect of surface quality, the results of the second series of tests show that electropolishing improves the performance when compared with the pickled qualities (2B or 2E). Both surface finishes are regarded as high quality, and all coupons were prepared with great care involving nitric acid passivation as the final treatment. Therefore, it is believed that the improved performance of the electropolished material is related to a marginally higher purity that possibly affects the passive dissolution rate.

The surface finish is a significant parameter for rouging, maybe even higher than the individual stainless steel grades.

Therefore when comparing the results of the EN 1.4435 coupons with the more highly alloyed steel types, there is no obvious improvement although the high alloyed steel types possess a significantly better corrosion resistance (mainly against chloride and acid attack). It is worth noting that the brushed coupons (2E) show at least the same amount of rouge as the EN 1.4435 coupons and even higher contents of dissolved iron. The electropolishing clearly improves the behavior of the high alloy steel types, and brings the overall performance up to a level of the best EN 1.4435 coupons. In fact the content of dissolved iron for the EN 1.4539 coupons was below the detection limit.

The surprisingly high amount of dissolved iron for the 2E-samples may be due to a higher passive dissolution rate for the high alloy materials in comparison

to EN 1.4435. Fundamental work on the passivation of stainless steel in acids shows that an increasing content of molybdenum may increase the passive dissolution rate [17], see Figure 11. However, this fact should only be considered as a possibility, since the boiling WFI is far less aggressive than the acids used to obtain these data.

An approach could be to set up an electrochemical test that enables quantification of the metal dissolution rate as function of exposure time. Based on the achieved results, the dissolution rate will correspond with a corrosion current of few nA/cm^2 . It would be very complicated (if possible) to measure such low currents in water with about $1 \mu S/cm$. Therefore, the measurement technique would have to be based on other principles than current measurement, e.g. electrochemical impedance spectroscopy (EIS). This technique can measure changes in the electrical properties of the passive film, and possibly characterize the adaptation of the passive film when subjected to environmental changes.

The fact that no corrosion was observed on any of the exposed coupons suggests that rouging is the result of slow metal dissolution while the stainless steel remains in its passive state. The possibility of finding any corrosion attack is also weakened by the limited amount of dissolved metals in the water samples.

It is believed that the release of metal (especially iron) is highest during the initial exposure period

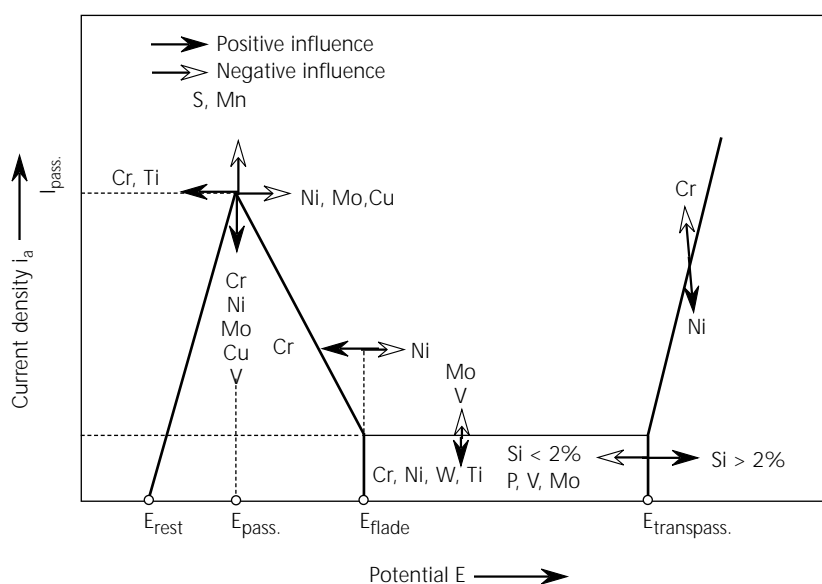

Fig 11. Schematic representation as to the influence of alloy elements on the current density vs. potential curve for stainless steel in acid.

where the driving force is high due to the low concentration of dissolved metals. Furthermore, the passive oxide film adapts its composition and structure to the surrounding environment during the first hours. This may also contribute to a high initial dissolution rate. The water analysis data and visual observations during exposure support this theory. After a certain period, steady state conditions are probably achieved in the exposure cell between the concentration of dissolved metals in the water and the composition of the passive oxide film. This situation differs from the one found in a real WFI system, where the water continuously is consumed and replaced. Therefore, it is considered that the dissolution of metal takes place at a higher rate than indicated by the exposure tests (i.e. less than $20 \mu\text{g}/\text{m}^2 \text{ day}$).

The established experimental technique has, with some success, made it possible to reproduce rouging in the laboratory and thereby study the effects of different parameters. It should be mentioned that the observed effect of the gas atmosphere previously had been shown using the same exposure technique but different evaluation methods [16]. Although interesting results were obtained, the technique is not yet considered perfect due to co-deposition of silicon released from the glass-ware. This side effect excluded the possibility of correlating the weight-gain of the coupons to the deposition of rouge, and may to

some extent also have affected the water chemistry. Moreover, the experimental technique is quite costly since each surface quality had to be tested separately with large number of coupons

for a long time to obtain a limited amount of rouge. Efforts are currently being made to refine the above technique and to pursue some of the interesting effects observed in this study.

CONCLUSIONS

Long-term tests of partly submerged stainless steel coupons have shown that the rouging phenomenon can be reproduced and studied in the laboratory.

Different surface finishes of EN 1.4435 steel exposed in boiling WFI purged with different gases showed that rouging develops faster in atmospheres of CO_2 containing air and N_2 . Purging with atmospheric air resulted in less rouging, while air minus CO_2 showed no visible rouge formation. The rouge formed was deposited preferentially along the water line or on Teflon parts. The rouge collected was in all cases identified as iron rich deposits. Furthermore, rouging was associated with increased amounts of dissolved metals in the test solution.

Exposure in N_2 purged WFI of the highly alloyed EN 1.4539 and EN 1.4462 steels in 2E finish showed no obvious improvement in performance when compared to the EN 1.4435 2B materials. The electropolished finish improved resistance against rouging and resulted in comparable behavior of the different steel types.

None of the exposed coupons showed significant weight loss or visible signs of localized corrosion. This suggests that rouging is mainly a result of passive dissolution and re-precipitation of metals, mainly iron. It also agrees well with the fact, that rouging may be intensified by any local defect, such as iron contamination, de-alloying or heat tints.

ACKNOWLEDGEMENTS

The companies of the authors financed the present study and contributed with materials and services. The author group is grateful to Novo Nordisk A/S, H. Lundbeck A/S, Gettinge Kemiterm A/S, Alfa-Laval Materials AB, Infraseriv Höchst and USF Ionpure AB who contributed to the initial part of the study.

Copyright

Reproduced with permission from NACE International, Houston, TX. All rights reserved. Paper No 03074 presented at Corrosion/2003, San Diego, CA. NACE International 2003.

REFERENCES

1. T. Self, P. Olsen, P. Banes, "Investigating the Rouging of Stainless Steel USP Water Systems", *Microcontamination*, Vol. 11, No. 5, 1993, pp. 44–55.
2. J.C. Tverberg, J.A. Ledden, "Rouging of Stainless Steel in WFI and High Purity Water Systems", *Proceedings of Tube 2000*, Düsseldorf, 2000.
3. G.R. Menon, "Rouge and Its Removal from High-Purity Water Systems", *BioPharm*, Vol. 3, No. 7, 1990, pp. 40–43.
4. A. Grant, B.K. Henon, F. Mansfeld, "Effects of purge gas purity and chelant passivation on the corrosion resistance of orbitally welded 316L stainless steel tubing", *Pharmaceutical Engineering*, Vol. 17, No. 1, 1997, pp. 46–60.
5. G. Henkel, "Edelstahl entrougen und repassivieren", CAV, Konradinverlag Germany, June 1999.
6. R.A. Corbett, "Rouging – A discoloration of Stainless Steel Surfaces", *Materials Performance*, Vol. 40, No. 2, 2001, pp. 64–66.
7. D.C. Coleman, R.W. Evans, "Corrosion Investigation of 316L Stainless Steel Pharmaceutical WFI Systems", *Pharmaceutical Engineering*, Vol. 11, No. 4, 1991, pp. 9–13.
8. R.W. Evans, D.C. Coleman, "Corrosion products in Pharmaceutical/Biotech Sanitary water systems", *Proceedings of Ultrapure Water EXPO '99*, Philadelphia, Pennsylvania, USA, April 8, 1999.
9. A.M.P. Jacobs, J.C.K. Lojengs, A.V.V. Sorge, "Stainless Steel: How long will it last?", *EHP*, Vol. 4, No 2, 1998, pp. 47–53.
10. R.W. Evans, D.C. Coleman, "Fundamentals of Passivation and Passivity in the Pharmaceutical Industry", *Pharmaceutical Engineering*, Vol. 10, No. 2, 1990, pp. 43–49.
11. B.K. Henon, "Recent Installation of WDI and WFI Process Piping Systems in a Biopharmaceutical Facility", *BED*, Vol. 23, *Bioprocess Engineering Symposium 1992*, ASME 1992, pp. 53–60.
12. O. Suzuki, D. Newberg, M. Inoue, "Discoloration and Its Prevention by Surface Treatment in High-Purity Water Systems", *Pharmaceutical Technology*, Vol. 22, No. 4, 1998, pp. 66–80.
13. P. Smith, "Derouging of Pharmaceutical Water Systems", *Proceedings of ISPE Seminar, Hygienic Process Systems*, Amsterdam, The Netherlands, 6th–7th Dec. 1999.
14. R.W. Evans, D.C. Coleman, "Pharmaceuticals. Corrosion products found in sanitary water systems – part 2", *Ultrapure Water*, Vol. 16, No. 10, 1999, pp. 34–38.
15. T. Mathiesen, J. Rau, J.E. Frantsen, J. Terävä, P. Björnstedt, B. Henkel, "Using Exposure Tests to Examine Rouging of Stainless Steel", *Pharmaceutical Engineering*, Vol. 22, No. 4, 2002, pp. 90–97.
16. C.Q. Jessen, "Project Rouge", Internal report of FORCE Institute, Denmark, 1997.
17. I.O. Edström, J.C. Carlén, S. Kämpinge, *Werkstoffe und Korrosion*, Vol. 21, 1970, pp. 812–821.

acom is distributed to persons actively involved in process industry development and other areas where stainless steels are important.

All rights reserved.

If you have any queries regarding acom, please contact me at jan.olsson@avestapolarit.com or by telephone on +46 (0) 226 812 48, fax +46 (0)226 813 05.

Jan Olsson

Technical Editor, acom
AvestaPolarit AB

AvestaPolarit AB
Research and Development
SE-774 80 Avesta, Sweden
Tel: +46 (0)226 810 00
Fax: +46 (0)226 813 05
www.avestapolarit.com